

Threaded Cross

Specification: ASME B16.11

Material: Available in a complete range of Carbon Steels, Stainless Steels, Alloy Steels and Non-ferrous metals certified to ASTM, ASME, and Military standards.

Sizes: 1/8" - 4" in CL 2000 and CL 3000 • 1/8" - 3-1/2" in CL 6000
Also available in CL 9000 and CL 10,000 and in reducing pipe sizes

Threads: American National Standard Taper Pipe Threads NPT (ANSI/ASME B1.20.1-1983)
Also available in other thread forms: NPTF, NPSC, NPSM, NGT, SAE, BSPT, BSPP and in any combination.
Left hand threads available upon request.

Threaded Pressure Class	Pipe Schedule
Class 2000	S80/XH
Class 3000	S160
Class 6000	XXH

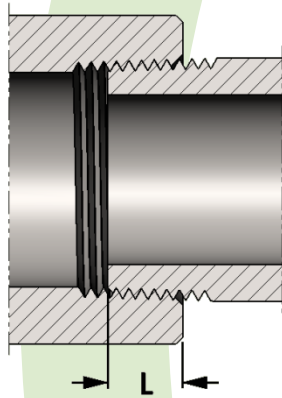

SIZE	L	SIZE	L
1/8	0.273	2	0.697
1/4	0.395	2-1/2	0.933
3/8	0.407	3	1.016
1/2	0.534	3-1/2	1.071
3/4	0.553	4	1.094
1	0.661	5	1.187
1-1/4	0.681	6	1.208
1-1/2	0.681	8	1.313

**Length of thread
screwed into fitting**

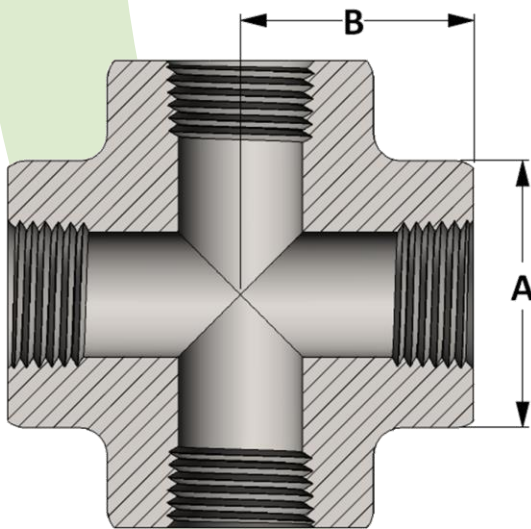

Active
3D
Model

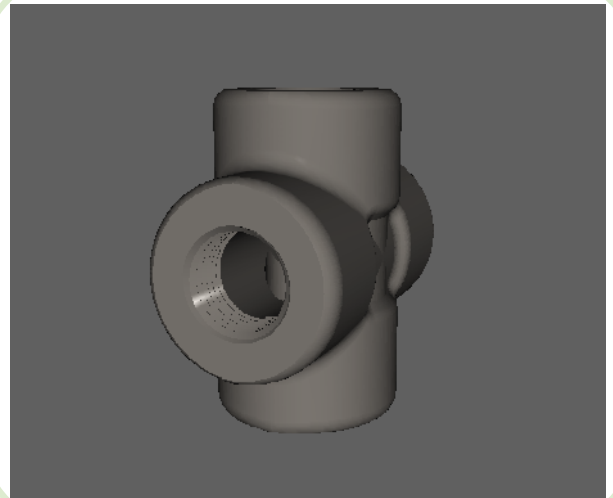

All dimensions are in inches • Weights are based on Carbon Steel

PIPE SIZE	CLASS 2000 – Figure No. 02004												
	1/8	1/4	3/8	1/2	3/4	1	1-1/4	1-1/2	2	2-1/2	3	3-1/2	4
A	1.063	1.063	1.063	1.313	1.500	1.813	2.188	2.500	3.000	3.625	4.313	---	5.875
B	0.969	0.969	0.969	1.125	1.313	1.500	1.750	2.000	2.375	3.000	3.375	---	4.188
LBS	0.54	0.52	0.40	0.84	1.20	1.67	2.48	3.41	5.51	16.66	27.90	---	33.28

PIPE SIZE	CLASS 3000 – Figure No. 03004												
	1/8	1/4	3/8	1/2	3/4	1	1-1/4	1-1/2	2	2-1/2	3	3-1/2	4
A	1.063	1.063	1.313	1.500	1.813	2.188	2.500	3.000	3.313	4.000	4.750	5.875	5.875
B	0.969	0.969	1.125	1.313	1.500	1.750	2.000	2.375	2.500	3.250	3.750	4.188	4.188
LBS	0.54	0.52	1.02	1.54	2.27	3.68	4.98	8.68	8.57	16.66	27.89	45.06	33.28

PIPE SIZE	CLASS 6000 – Figure No. 06004												
	1/8	1/4	3/8	1/2	3/4	1	1-1/4	1-1/2	2	2-1/2	3	3-1/2	4
A	1.063	1.313	1.500	1.813	2.188	2.500	3.000	3.313	4.000	4.750	5.875	5.875	---
B	0.969	1.125	1.313	1.500	1.750	2.000	2.375	2.500	3.250	3.750	4.188	4.188	---
LBS	0.54	1.14	1.71	2.67	4.38	5.92	10.15	11.65	21.71	36.85	54.83	45.06	---